

PARTS DIVISION AND PARTS LIST

A: COLUMN PART

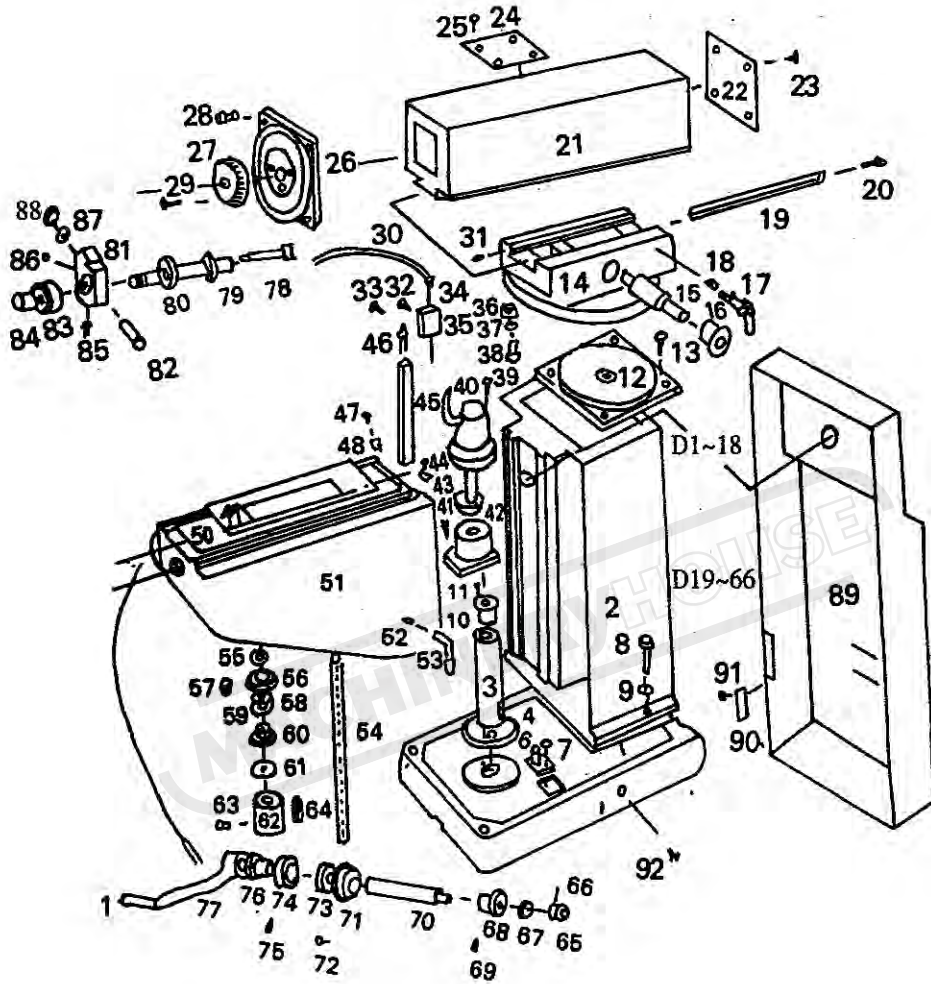

(optional accessory: cooling system)

B: Rotary table (optional)

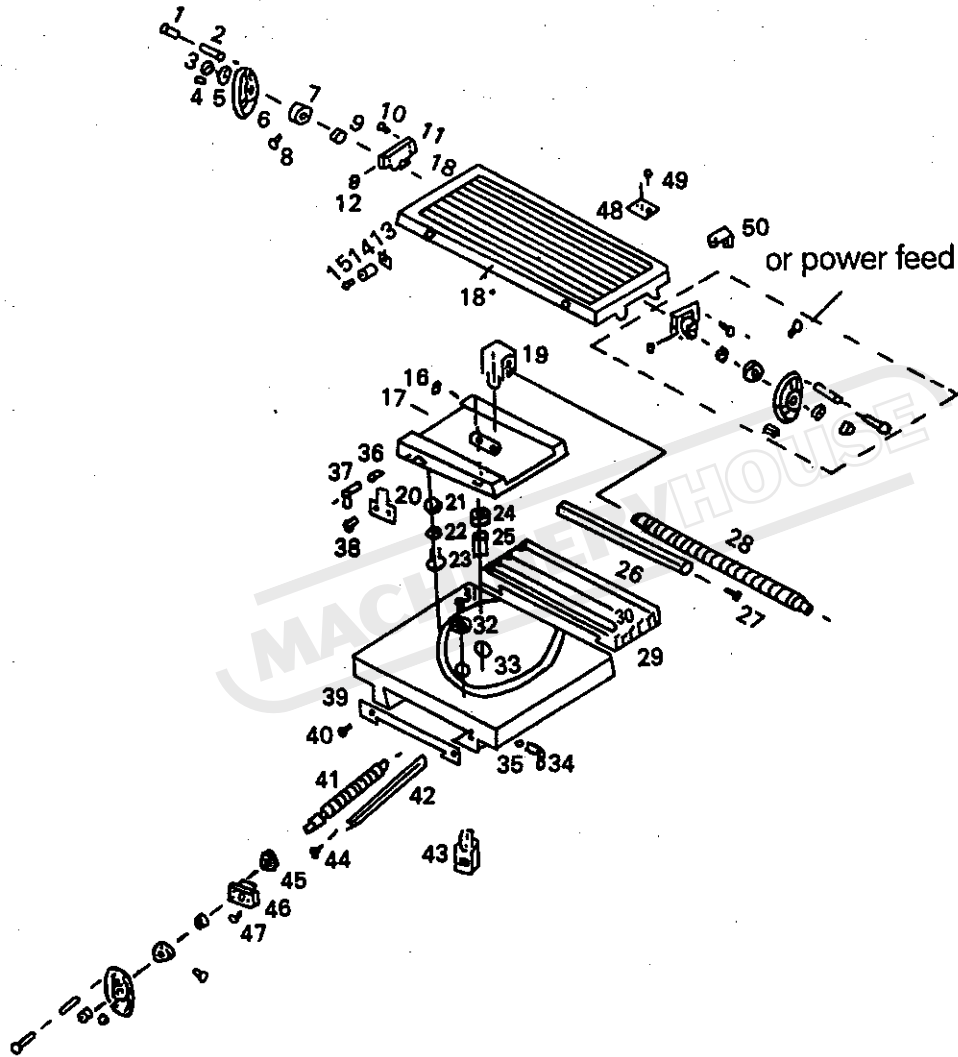

C: HEAD PART--- 1PH

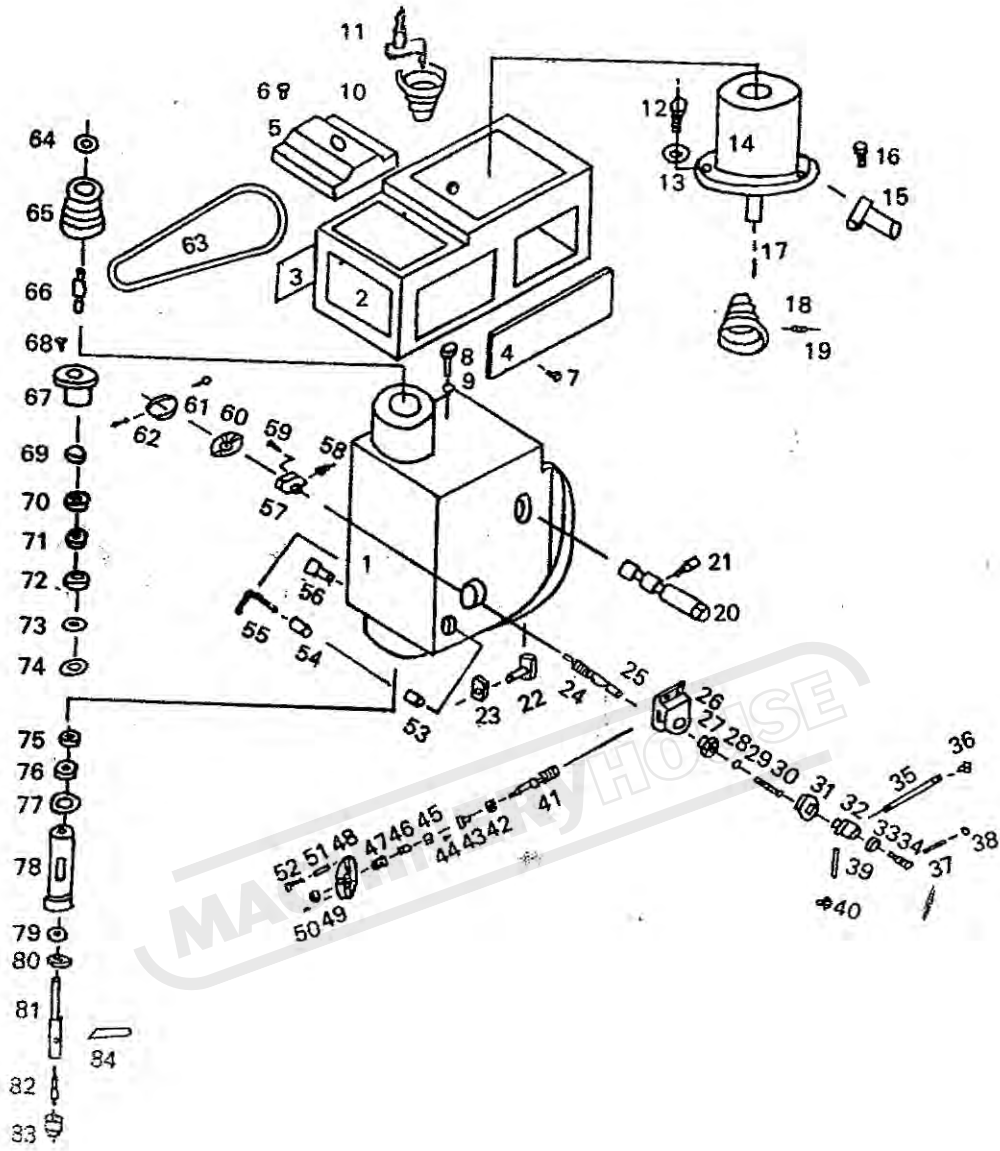

D: HORIZONTAL SPINDLE PART

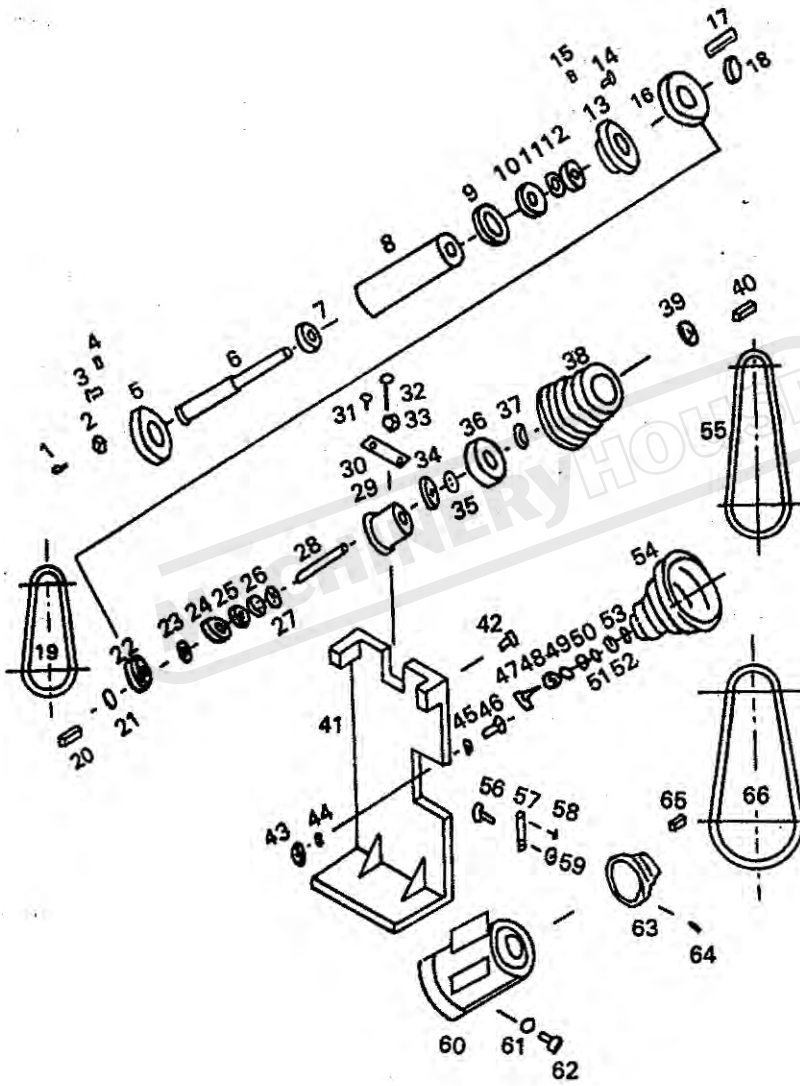

E: Gear box

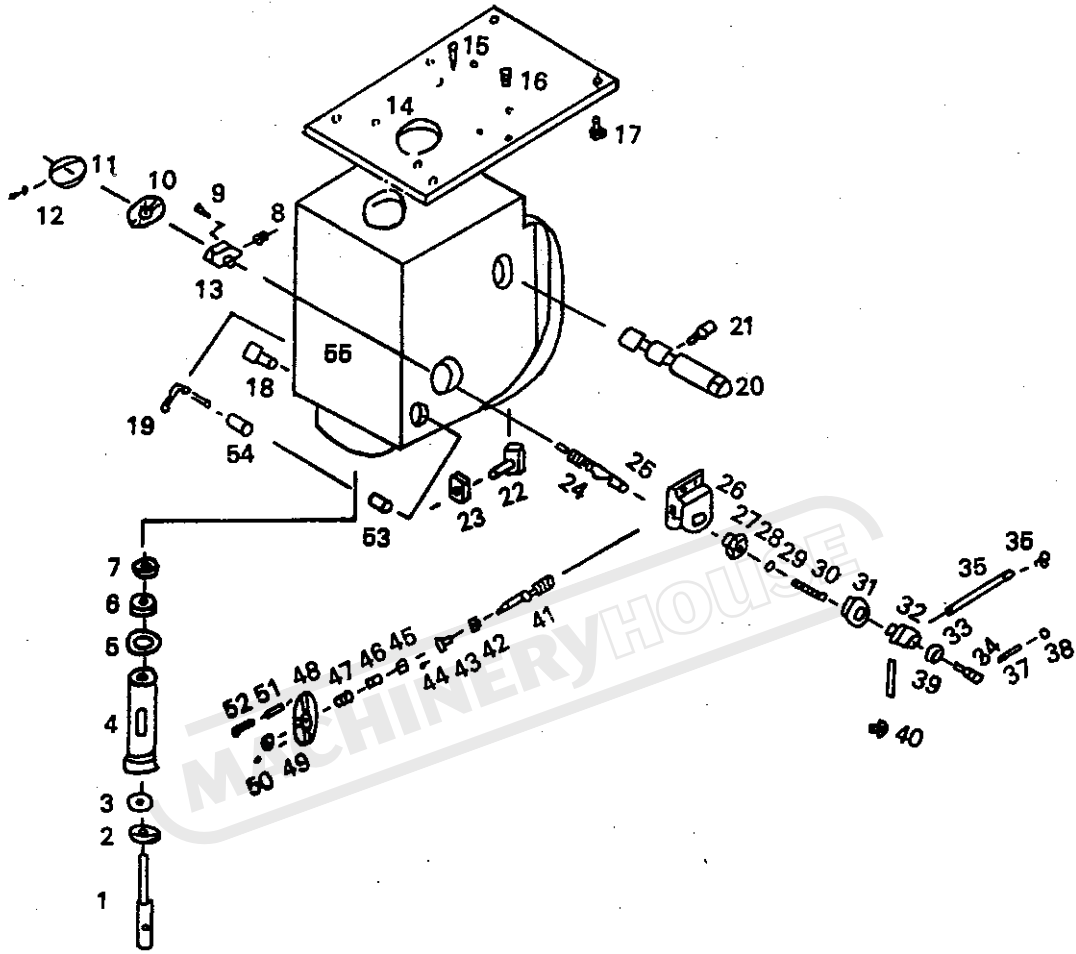

F: Gear head

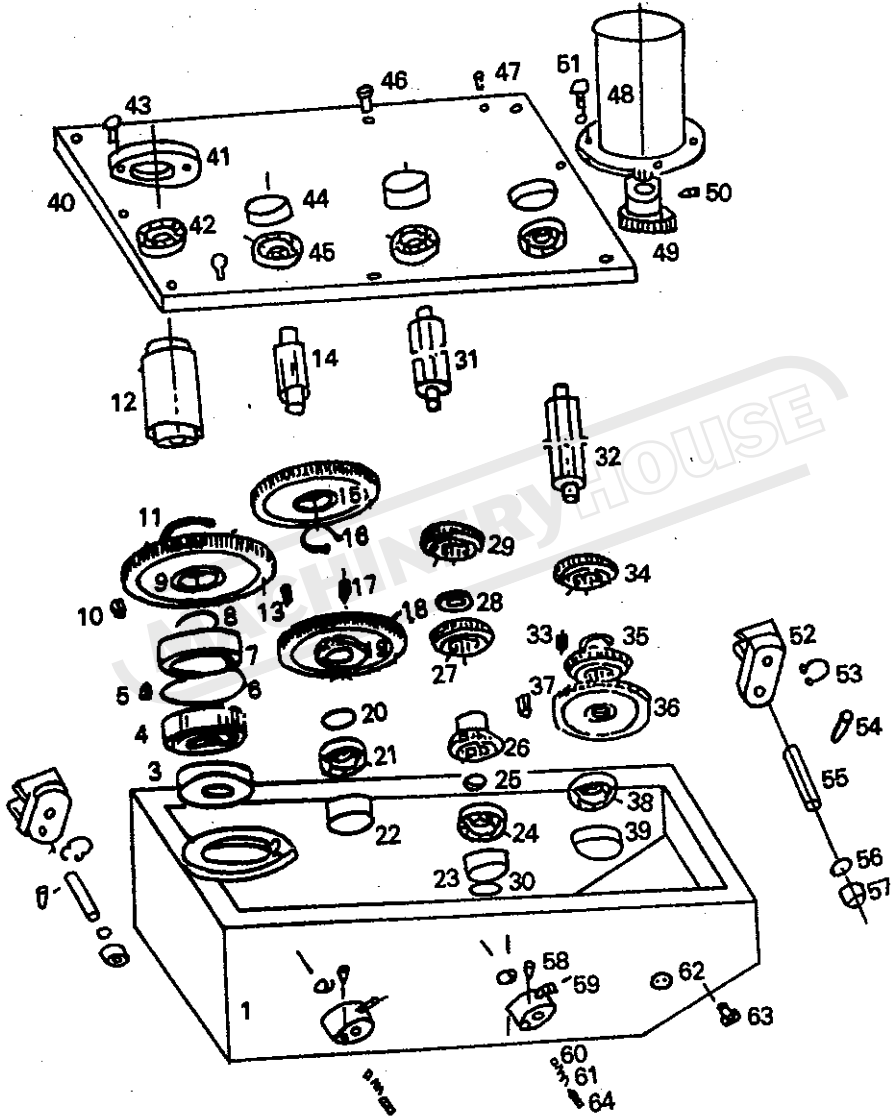

G: Table

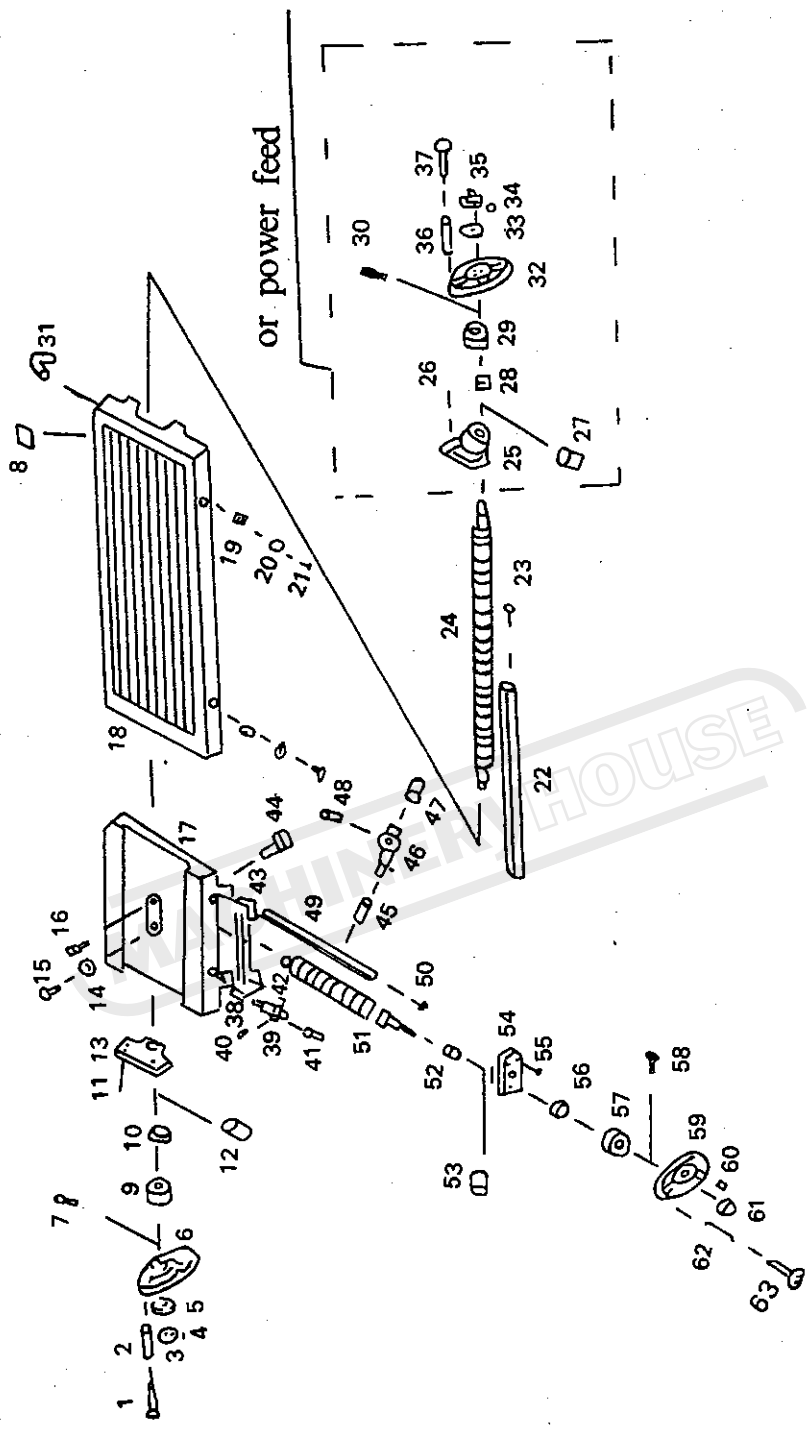

NUMBERP	NAME	QUANTITY
A1	BASE	1
2	COLUMN	1
3	ELEVATING SCREW HOUSING	1
4	SCREW	4
5	WASHER	4
6	CONNECT TUBE	1
7	SCREW	2
8	BOLT	6
9	WASHER	6
10	COLLAR	1
11	SCREW	4
12	HOLD SURREORT	1
13	SCREW	6
14	AROUND BRACKET	1
15	FEED SHAFT	1
16	COLLAR	1
17	CLAMP BOLT	2
18	CLAMP BLOCK	2
19	BEVEL IRON	1
20	SCREW	1
21	OVERARM	1
22	COVER	1
23	SCREW	4
24	COVER	1
25	SCREW	4
26	HOLD BRACKET	1
27	GEAR	1
28	SCREW	4
29	BOLT	2
30	NOZZLE	1
31	OIL CUP	2

NUMBERP	NAME	QUANTITY
32	SCREW	2
33	BOLT	1
34	CONNECT TUBE	1
35	HOLD BRACKET	1
36	NUT	4
37	WASHER	4
38	T BOLT	4
39	BOLT	4
40	ELECTRIC PUMP	1
41	BOLT	4
42	SUPPORT	1
43	DUST COVER	1
44	SCREW	2
45	BEVEL IRON	1
46	ADJUST SCREW	1
47	SCREW	2
48	WIPER PLATE	1
49	WIPER PLATE	1
50	WIPER PLATE	2
51	KNEE	1
52	CLAMP BLOCK	2
53	CLAMP BOLT	2
54	HOIST DESCEND LEAD SCREW	1
55	CIRCULAR NUT	2
56	CONICAL GEAR	1
57	KEY	1
58	BALL BEARING	1
59	ADJUST WASHER	1
60	COLLAR	1
61	BALL BEARING	1
62	NUT	1

NUMBERP	NAME	QUANTITY
63	SCREW	1
64	KEY	1
65	CONECAL GEAR	1
66	PIN	1
67	WASHER	1
68	COLLAR	1
69	SCREW	1
70	SHAFT	1
71	COLLAR	1
72	SCREW	4
73	BALL BEARINGP	1
74	SCALE RING	1
75	SCREW	1
76	COLLAR	1
77	HANDLE	1
78	LIFT BAR	1
79	TOOLHOLDER	2
80	CUTTER BAR COLLAR	10
81	SUPPORT	1
82	BOLT	1
83	COLLAR	1
84	NUT	1
85	SCREW	1
86	OIL CUP	1
87	WASHER	1
88	NUT	1
89	BEHIND COVER	1
90	HINGE	2
91	SCREW	16
92	SCREW	1

NUMBERP	NAME	QUANTITY
B1	HANDLE	3
2	HANDLE COLLAR	3
3	NUT	3
4	KEY	3
5	WASHER	3
6	HAND WHEEL	3
7	SCALE RING	3
8	SCREW	3
9	BEARING	3
10	SCREW	10
11	SUPPORT	2
12	OIL CUP	3
13	SCREW BRACKET	2
14	DOG	2
15	SCREW	2
16	OIL CUP	2
17	ROTARY BRACKET	1
18	TABLE	1
19	NUT	1
20	LIMIT ASSEMBLY	1
21	NUT	1
22	WASHER	4
23	T - BOLT	4
24	SHAFT MOUNT	1
25	SHAFT	1
26	LONG BEVEL IRON	1
27	ADJUST SCREW	1
28	LONGITUD INALLEAD SCREW	1
29	WAY COVER	

NUMBERP	NAME	QUANTITY
C1	SPINDLE BOX	1
2	MOTOR BASE	1
3	LEFT COVER	1
4	RIGHT COVER	1
5	PULLEY COVER	1
6	SCREW	4
7	SCREW	4
8	BOLT	6
9	WASHER	6
10	Center Pulley	1
11	Center Pulley Shaft <i>Parts</i>	1
12	BOLT	2
13	WASHER	1
14	MOTOR	1
15	HANDLE	1
16	BOLT	2
17	KEY	1
18	MOTOR PULLEY	1
19	HEADLESS SEAT SCREW	1
20	WORM GEAR	1
21	PIN	1
22	T BOLT	3
23	NUT	1
24	FEED SHAFT	1
25	KEY	1
26	WORM BOX	1
27	SCREW	3
28	BEVEL GEAR	1
29	RETAINING RING	1
30	SPRING	1
31	SCALE RING	1

NUMBERP	NAME	QUANTITY
32	HANDLE BRACKET	1
33	COVER	1
34	BOLT	1
35	HANDLE BAR	3
36	KNOB	3
37	HANDLE	1
38	HANDLE COLLAR	1
39	SCALE	1
40	RIVET	2
41	WORM GEAR	1
42	BALL BEARING	1
43	SMALL COVER	1
44	SCREW	3
45	BALL BEARING	1
46	COLLAR	1
47	SCALE RING	1
48	HANDLE WHEEL	1
49	HANDLE COLLAR	1
50	HANDLE	1
51	NUT	1
52	KEY	1
53	CLAMP BLOCK	1
54	CLAMP BLOCK	1
55	CLAMP HANDLE	1
56	SCREW	1
57	SPRING SEAT	1
58	SCREW	1
59	SCREW	1
60	SPRING PLATE	1
61	SPRING CAP	1
62	SCREW	2

NUMBERP	NAME	QUANTITY
D1	SCREW	4
2	KEY	2
3	SCREW	4
4	OIL CUP	1
5	COVER	1
6	SPINDLE	1
7	BALL BEARING	1
8	COLLAR	1
9	BALL BEARING	1
10	WASHER	1
11	WASHER	1
12	NUT	1
13	COVER	1
14	SCREW	4
15	OIL CUP	1
16	SPINDLE PULLEY	2
17	KEY	1
18	RETAINING RING	1
19	V BELT	2
20	KEY	1
21	RETAINING RING	1
22	WHEEL	1
23	BALL BEARING	1
24	BALL BEARING	1
25	BALL BEARING	1
26	COLLAR	1
27	BALL BEARING	1
28	SMALL SHAFT	1
29	COLLAR	1
30	SUPPORT	1
31	SCREW	2

NUMBERP	NAME	QUANTITY
32	BOLT	1
33	NUT	1
34	RETAINING RING	1
35	RETAINING RING	1
36	NUT	2
37	RETAINING RING	1
38	PULLEY	1
39	RETAINING RING	1
40	KEY	1
41	MOTOR BASE	1
42	SCREW	6
43	NUT	1
44	WASHER	1
45	WASHER	1
46	SMALL SHAFT	1
47	CONNECT	1
48	REAINING RING	1
49	BALL BEARING	1
50	COLLAR	1
51	BALL BEARING	1
52	RETAINING RING	1
53	RETAINING RING	1
54	PULLEY	1
55	V—BELT	1
56	ADJUST SCREW	1
57	SUPPORT	1
58	SCREW	1
59	NUT	1
60	MOTOR	1
61	WASHER	4
62	BOLT	4

E: GEAR BOX

NUMBERP	NAME	QUANTITY
E1	SPINDLE	1
2	DUST COVER	1
3	BEARING	1
4	SLEEVE	1
5	BEARING	1
6	WASHER	1
7	NUT	1
8	SCREW	1
9	SCREW	1
10	SPRING PLATE	1
11	SPRING CAP	1
12	SCREW	1
13	SPRING SEAT	1
14	BASE	1
15	PIN	2
16	SCREW	6
17	SCREW	6
18	BOLT	1
19	CLAMP HANDLE	1
20	WORM GEAR	1
21	PIN	1
22	T—BOLT	3
23	NUT	3
24	FEED SHAFT	1
25	KEY	1
26	WORM BOX	1
27	SCREW	3
28	BEVEL GEAR	1
29	CRESCENT RING	1
30	SPRING	1

NUMBERP	NAME	QUANTITY
31	SCALE RING	1
32	HANDLE BRACKET	1
33	COVER	1
34	BOLT	1
35	HANDLE BAR	3
36	KNOB	3
37	HANDLE	1
38	HANDLE COLLAR	1
39	SCALE	1
40	RIVET	2
41	WORM GEAR	1
42	BEARING	1
43	SMALL COVER	1
44	SCREW	3
45	BEARING	1
46	COLLAR	1
47	SCALE RING	1
48	HANDLE WHEEL	1
49	HANDLE	1
50	HANDLE	1
51	NUT	1
52	KEY	1
53	CLAMP BLOCK	1
54	CLAMP HANDLE	1
55	BOX	1

GEAR HEAD

NUMBERP	NAME	QUANTITY
F1	BOX	1
2	COLLAR	1
3	OIL SEAL	1
4	BALL BEARING	1
5	SCREW	1
6	O—RING	1
7	COLLAR	1
8	RETAINING RING	1
9	GEAR	1
10	KEY	1
11	RETAINING RING	1
12	SHAFT	1
13	KEY	1
14	DRIVING SHAFT	1
15	GEAR	1
16	RETAINING RING	1
17	SCREW	1
18	GEAR	1
19	GEAR	1
20	O—RING	2
21	BALL BEARING	1
22	COLLAR	1
23	COLLAR	1
24	BALL BEARING	1
25	RETAINING RING	1
26	GEAR	1
27	GEAR	1
28	COLLAR	1
29	GEAR	1
30	O—RING	1

NUMBERP	NAME	QUANTITY
31	DRIVING SHAFT	1
32	DRIVING SHAFT	1
33	SCREW	1
34	GEAR	1
35	GEAR	1
36	GEAR	1
37	KEY	1
38	BEARING	1
39	COLLAR	1
40	BOX COVER	1
41	COLLAR	1
42	BEARING	1
43	SCREW	4
44	COLLAR	3
45	BEARING	3
46	SCREW	6
47	PIN	2
48	MOTOR	1
49	GEAR	1
50	SCREW	1
51	BOLT	4
52	LIFT FORK	2
53	CRESCENT RING	2
54	PIN	2
55	SHAFT	2
56	O—RING	2
57	COLLAR	2
58	PIN	2
59	HANDLE	2
60	BALL	2
61	SPRING	1
62	OIL POSITION	1
63	BOLT	1
64	SCREW	2

NUMBERP	NAME	QUANTITY
G1	HANDLE	1
2	HANDLE COLLAR	1
3	NUT	1
4	KEY	1
5	WASHER	1
6	HAND WHEEL	1
7	SCREW	1
8	OIL COVER	1
9	SCALE RING	1
10	BALL BEARING	1
11	SCREW	1
12	OIL CUP	1
13	SUPPORT	1
14	WASHER	1
15	SCREW	1
16	NUT	1
17	SADDLE	1
18	TABLE	1
19	SCREW BRACKET	2
20	DOG	2
21	SCREW	2
22	LONG BEVEL IRON	1
23	ADJUST SCREW	1
24	BALL SCREW	1
25	SUPPORT	1
26	SCREW	4
27	OIL CUP	1
28	BALL BEARING	1
29	SCALE RING	1

NUMBERP	NAME	QUANTITY
30	SCREW	1
31	CONNECT TUBE	1
32	HAND WHEEL	1
33	WASHER	1
34	KEY	1
35	NUT	1
36	HADLE COLLAR	1
37	HANDLE	2
38	CLAMP BLOCK	2
39	PIN	2
40	SCREW	2
41	HAND BOARD	2
42	SCREW	3
43	WIPER PLATE	2
44	NUT	1
45	CLAMP BLOCK	2
46	SCREW	2
47	HANDBOARD	2
48	PIN	2
49	BEVEL IRON	1
50	ADJUST SCREW	1
51	BALL SCREW	1
52	BALL BEARING	1
53	OIL CUP	1
54	SUPPORT	1
55	SCREW	1
56	BALL BEARING	1
57	SCALE RING	1
58	SCREW	

Installation

FOUNDATION PLAN

Ideally this machine should be bolted to a concrete foundation. The machine should be placed on a solid level floor or anti-vibration pads to prevent any rocking movement.

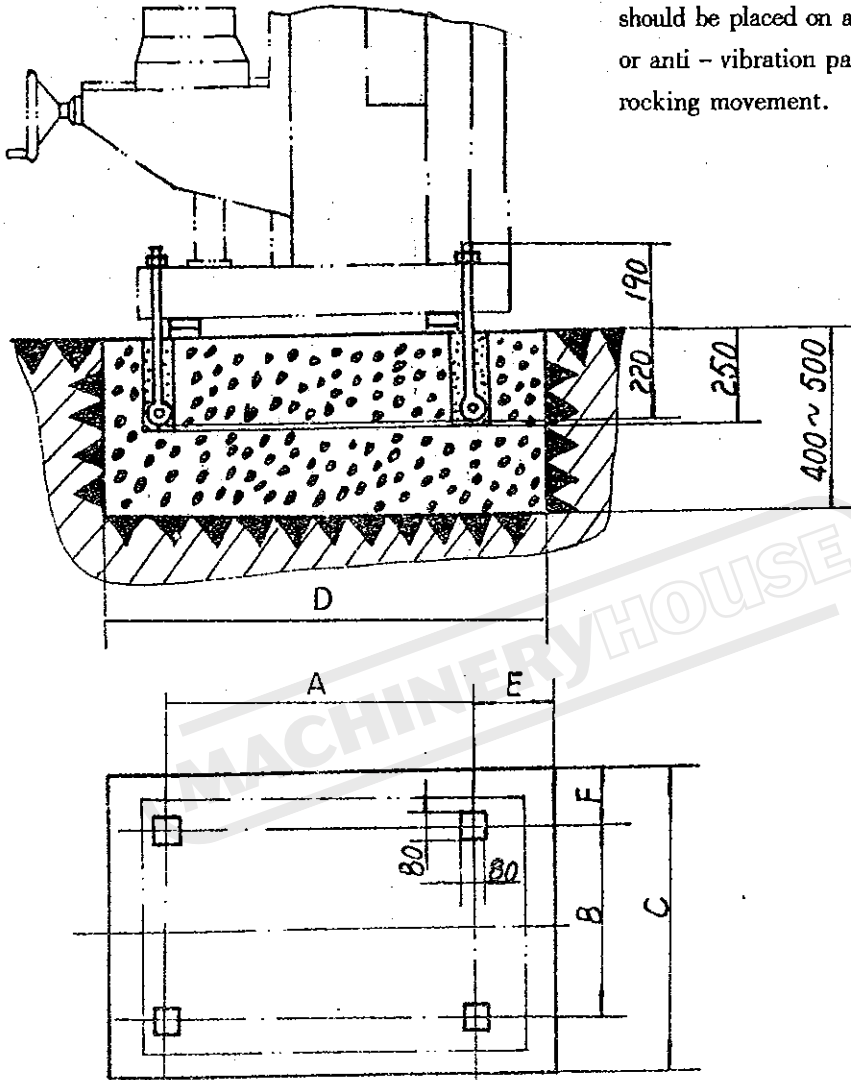

MODEL	A	B	C	D	E	F
HM50	678	445	745	1110	220	150
HM52'	845	466	760	1285	220	150

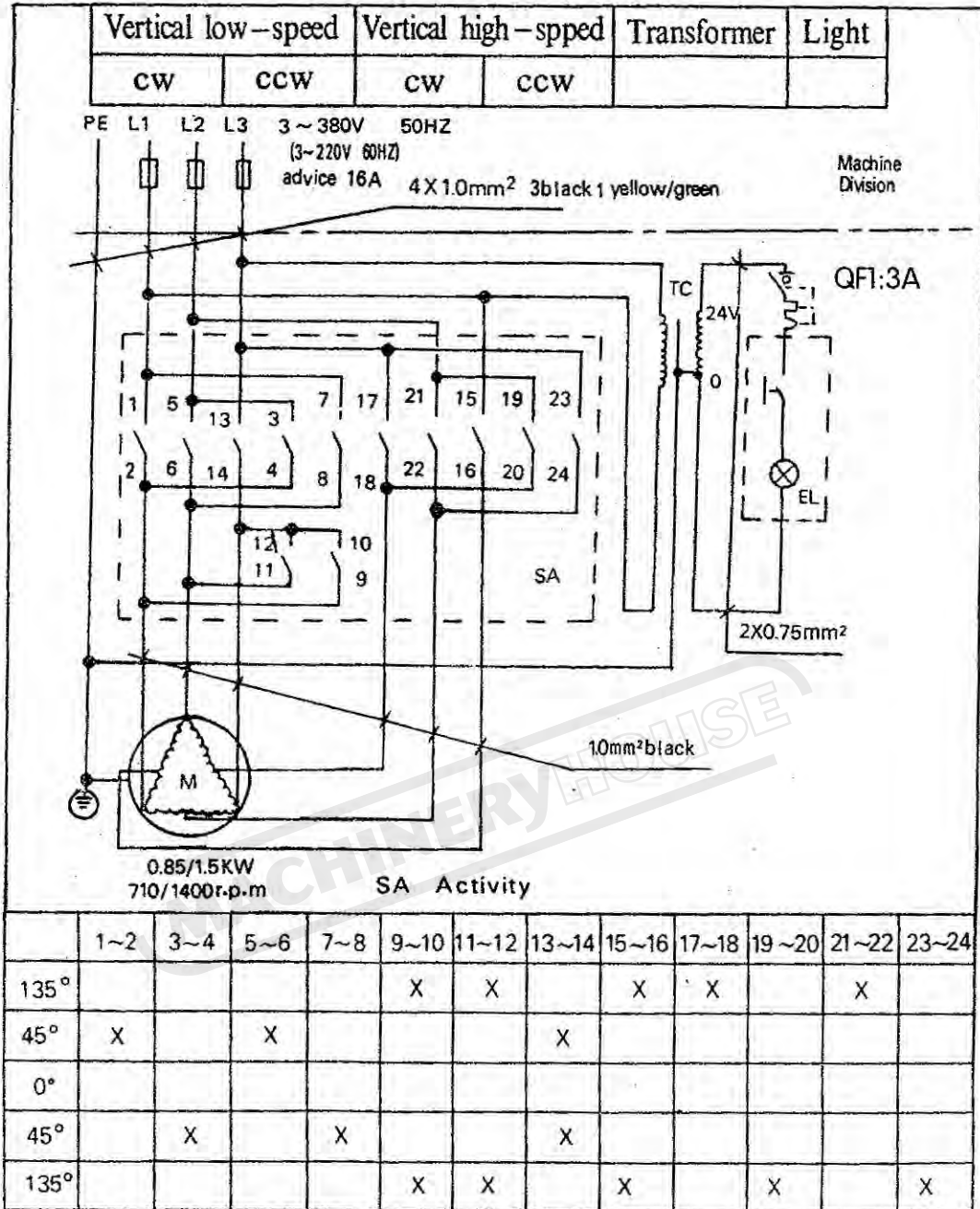

Used

When power voltage of 220V 60HZ, the motor's voltage, transformer's input and Ac contactor will be changed into 220V 60HZ, the others unchanged.

COMPONENTS LIST

Item	code	Name	Model or specification	Quantity	Note
1	M1	Three—phase induction motor (Vertical)	YD100L—8/4 3PH 380V 50HZ 0.85/1.5kw 710/1400r. p. m v1	1	
2	QF	Circuit breaker	DZ47—63(1P 3A)	1	
3	TC	Transformer	JBK4—63 63VA 0—220V I: 0—380V 0:0—24V 63VA	1	
4	SA1	Combination Switch (for vertical mill control)	LW5—16/5.5SN/6 Ue:500V Ie:16A	1	
5	EL	Light	JC11—1E27(AC: 24V 40W)	1	
		Halogen lamp	JC—38(50W AC: 24V)	1	optional accessory

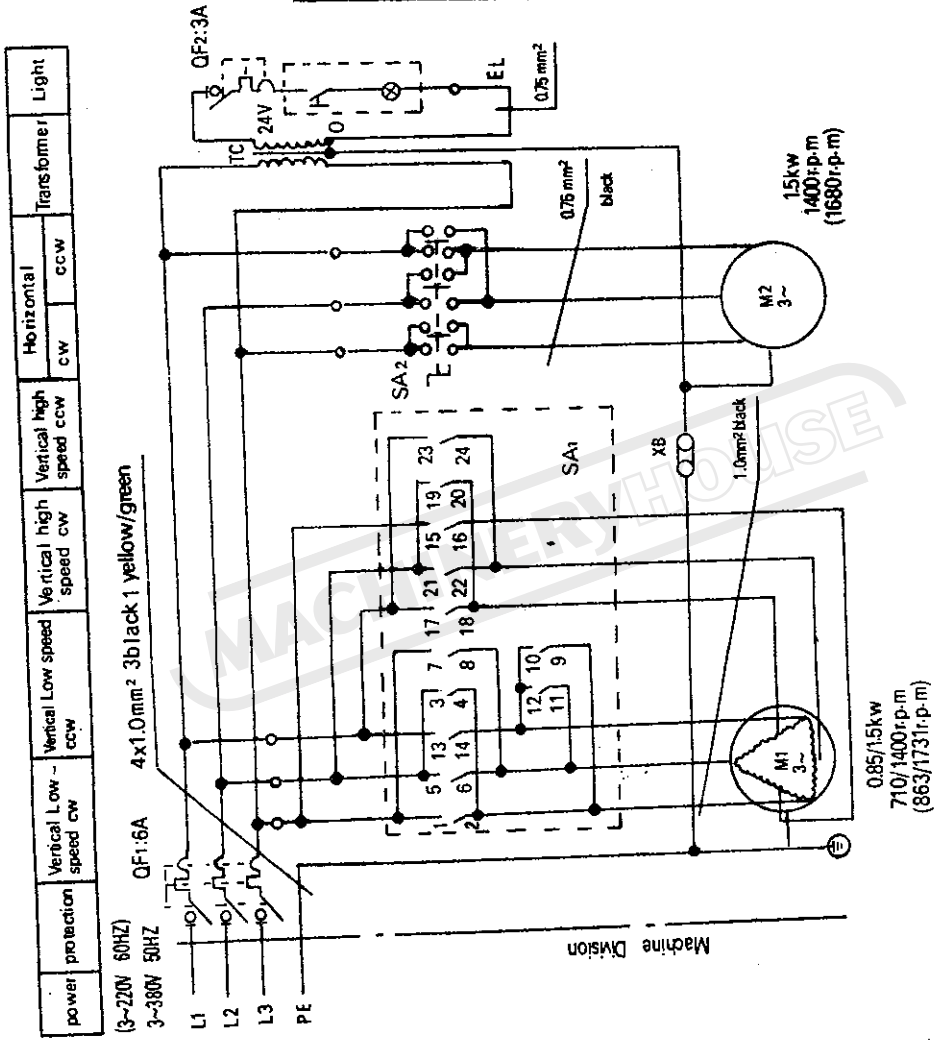

SAI Activity

	135°	45°	0°	45°	135°
1~2		X			
3~4			X		
5~6				X	
7~8					X
9~10	X				
11~12	X				
13~14			X		
15~16		X			X
17~18		X			X
19~20					X
21~22	X				
23~24					X

When power volatage of 220V 60HZ used, the motor's Volatage and the transformer's input will be changed into 220V 60HZ, the others unchanged.

COMPONENTS LIST

Item	code	Name	Model or specification	Quantity	Note
1	M1	Three—phase induction motor (Vertical)	YD100L—8/4 3PH 380V 50HZ 0.85/1.5KW 710/1400r. p. m V1	1	
2	M2	Three—phase induction motor (Horizontal)	Y90L—4 3PH 380V 50HZ 1.5KW 1400r. p. m B3	1	
3	QF1	circuit breaker	DZ47—63 (3P 6A)	1	
4	QF2	Circuit breaker	DZ47—63 (1P 3A)	1	
5	SA1	Combination Switch (for vertical mill control)	LW5—16/5.5SN/6 Ue:500V Ie:16A	1	
6	SA2	Combination Switch	HZ5B—10/3DO22 Ue:380V Ie:10A	1	
7	TC	Transformer	JBK4—63 63VA I: 0—220V 0—380V D:0—24V 60VA	1	
8	EL	Light	JC11—1E27 (AC; 24V 40W)	1	
		Halogen lamp	JC—38 (AC:24V 50W)	1	optional accessory

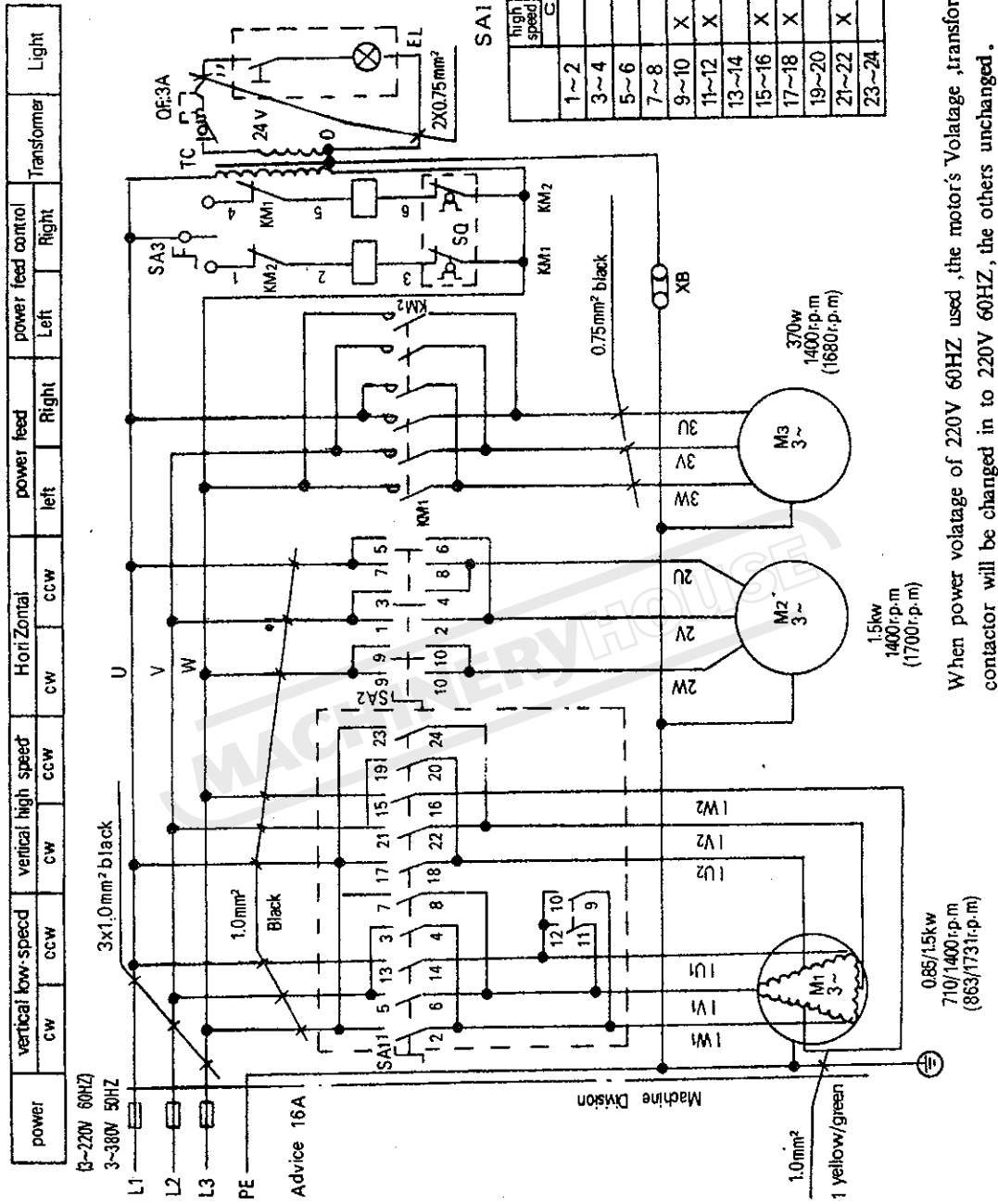

SAI Activity

	High speed		LOW speed		Off
	GW	CCW	GW	CCW	
1~2	X			X	
3~4			X		
5~6			X		
7~8				X	
9~10	X				X
11~12	X				X
13~14			X		
15~16	X				X
17~18	X				X
19~20			X		
21~22	X				X
23~24					X

When power voltage of 220V 60HZ used, the motor's Voltage, transformer's input and Ac contactor will be changed in to 220V 60HZ, the others unchanged.

COMPONENTS LIST

Item	code	Name	Model or specification	Quantity	Note
1	M1	Three—phase induction motor (Vertical)	YD100L—8/4 3PH 380V 50HZ 0.85/1.5KW 710/1400r. p. m V1	1	
2	M2	Three—phase induction motor (Horizontal)	Y90L—4 3PH 380V 50HZ 1.5KW 1400r. p. m B3	1	
3	M3	Three—phase induction motor (power feed)	YS—7124 AC;3PH 380V 50HZ 370W 1400r. p. m B5	1	
4	KM1 KM2	AC contactor	CJX1—9/22 AC;380V 50HZ	2	
5	SA1	Combination Switch (for vertical mill control)	LW5—16/5.5SN/6 Ue;500V Ie;16A	1	
6	SA2	Combination Switch (for Horizontal mill control)	HZ5B—10/3DO22 Ue;380V Ie;10A	1	
7	SA3	Combination Switch (for power feed control)	LA18—22X3 Ie;5A	1	
8	QF	Circuit breaker	DZ47—63(1P 3A)	1	
9	TC	Transformer	JBK4—63 60VA 0—220V I:0—380V D:0—24V 60VA	1	
10	EL	Light	JC11—1E27 (AC; 24V 40W)	1	
		Halogen lamp	JC—38 (AC;24V 50W)	1	optional accessory

power: power switch	vertical low-speed	vertical high-speed	power feed left	power feed right	power feed control	protection E-stop	Transformer	Light
3-225V 60HZ; 3-380V 50HZ	CW CCW	CW CCW	left right	left right	Left Right stop			

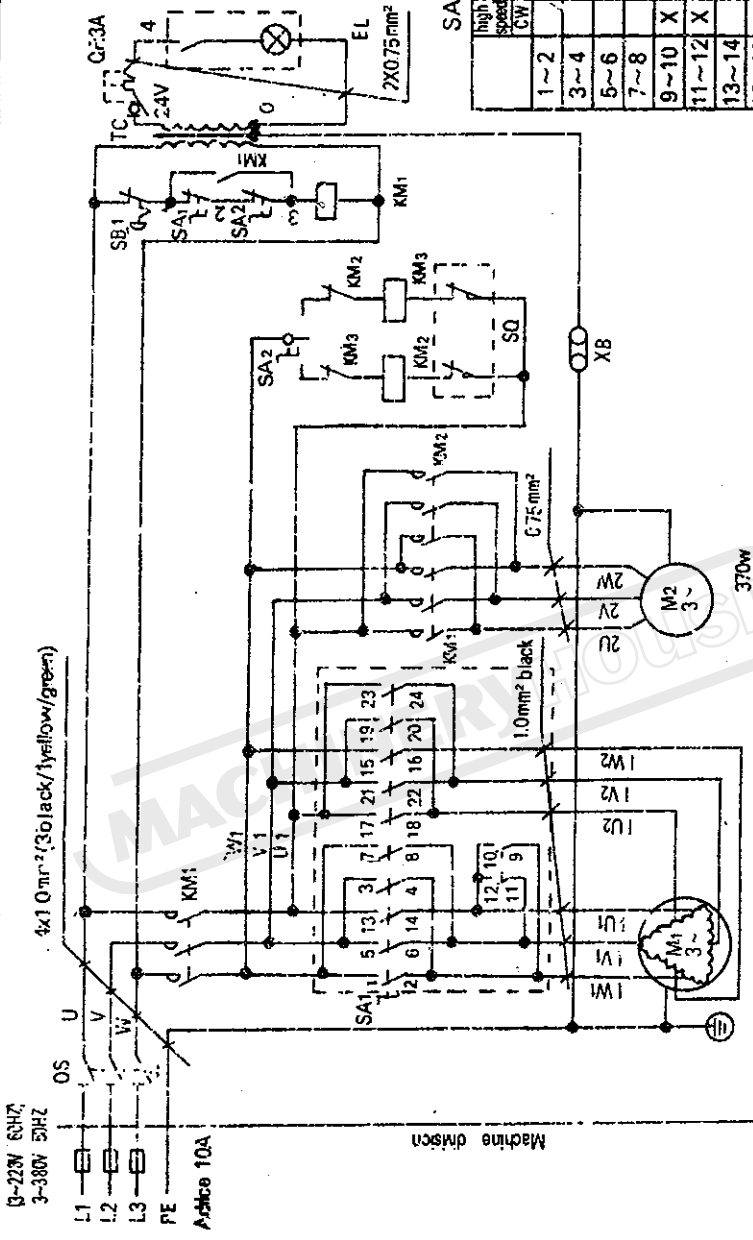

SA1 Activity

	high speed CW	LOW speed CW	OFF	LOW speed CCW	OFF	high speed CCW
1~2		X				
3~4				X		
5~6				X		
7~8					X	
9~10	X					X
11~12	X					X
13~14		X				
15~16	X					X
17~18	X					X
19~20						X
21~22	X					X
23~24						X
25~26	X			X		X
27~28						

Machine driven

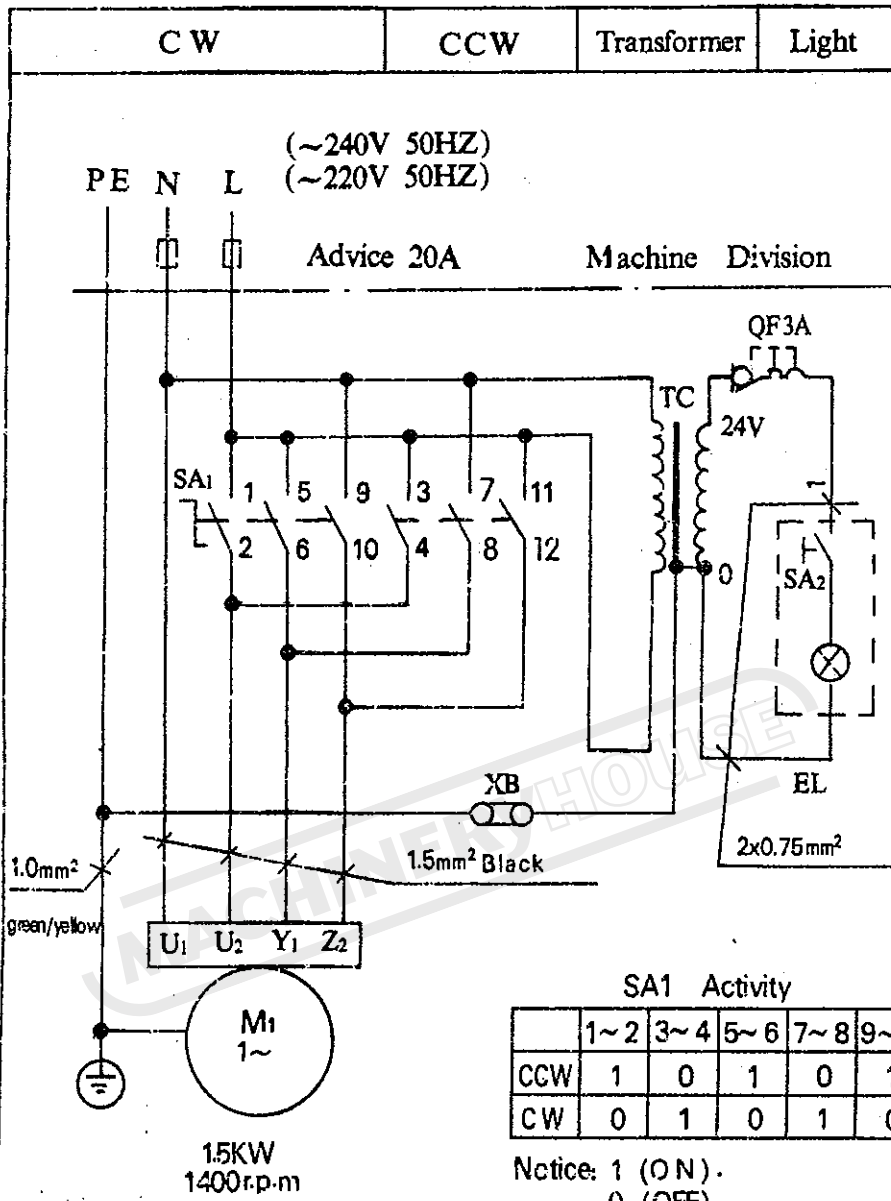

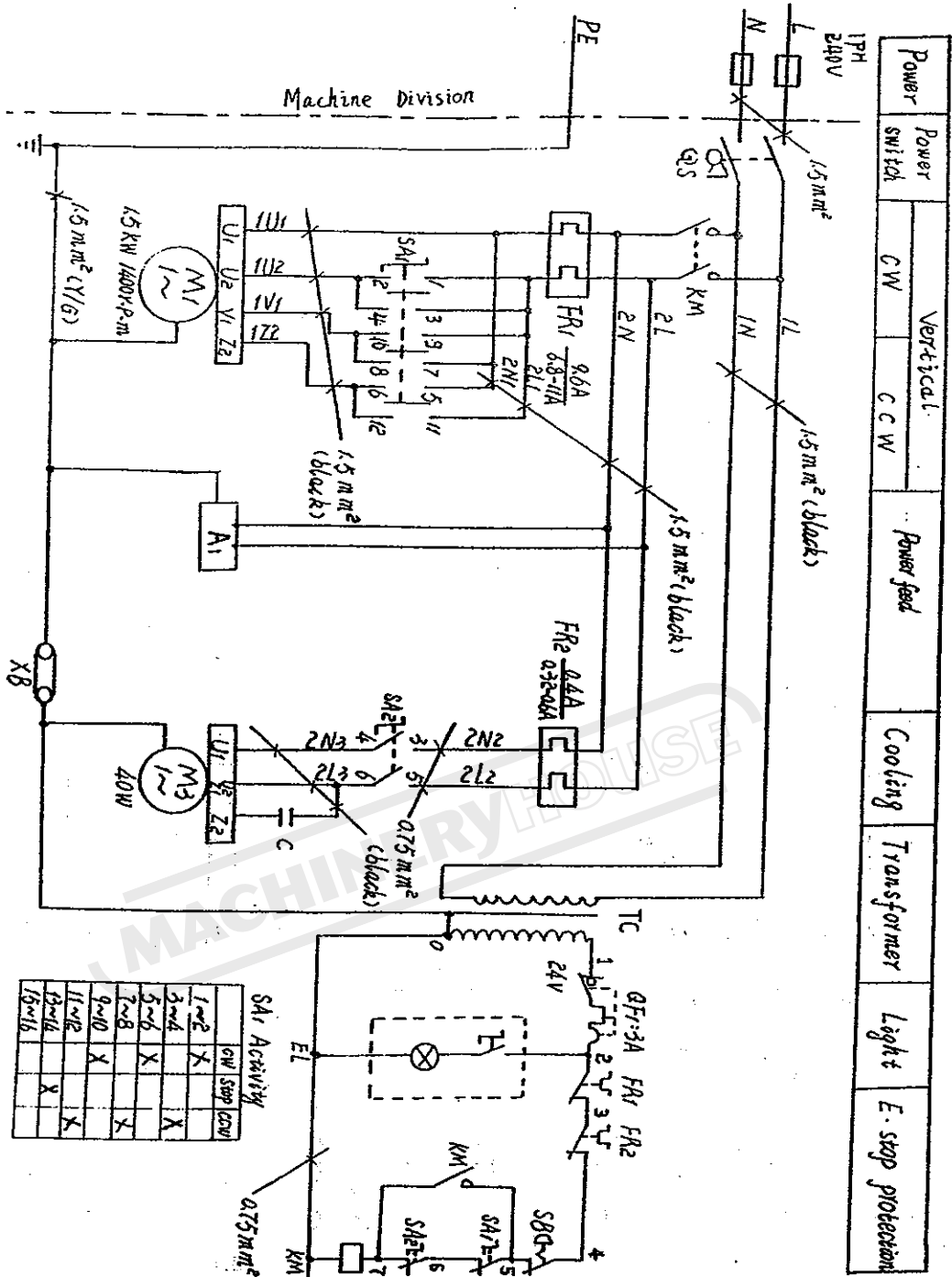

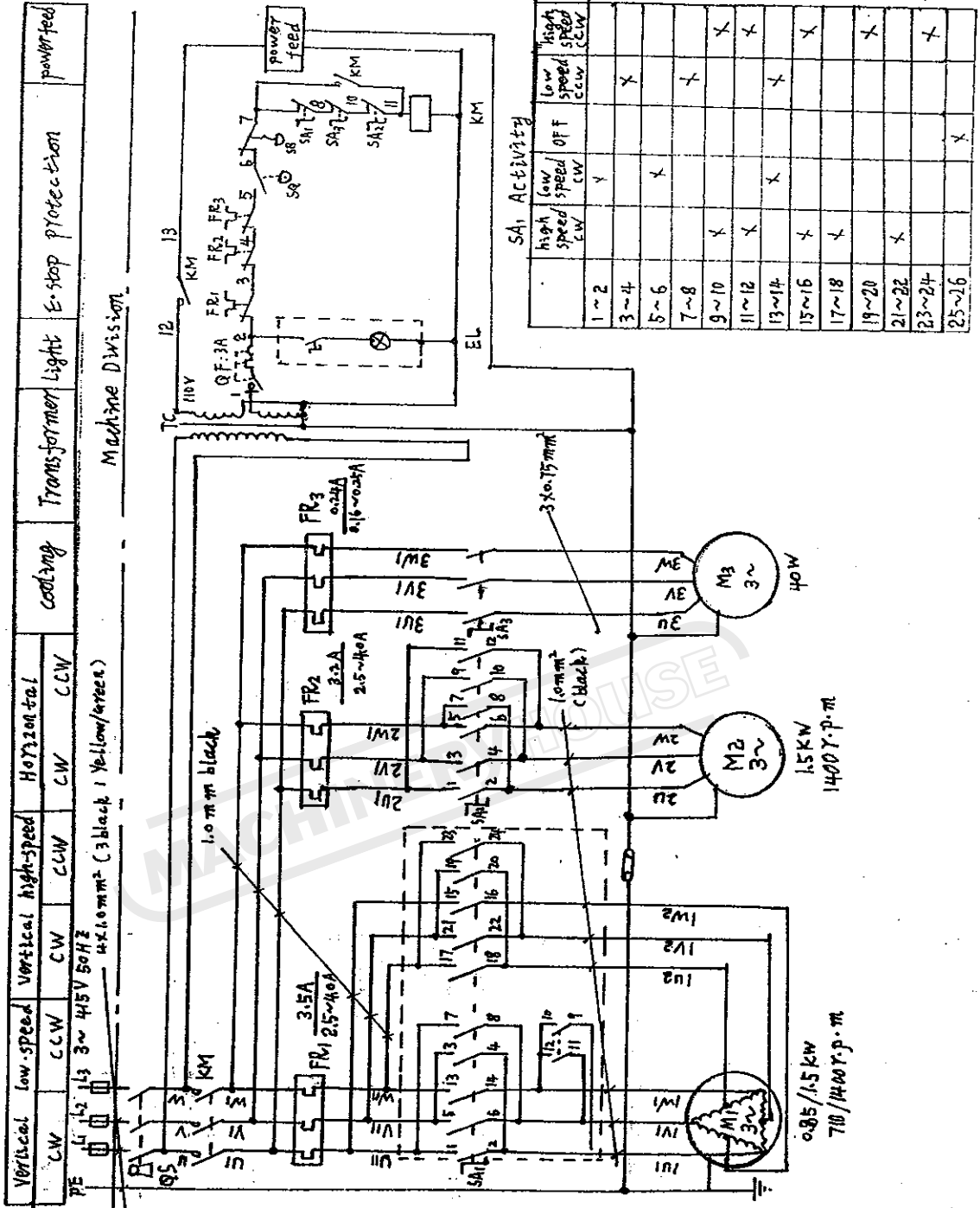

Vertical low-speed		Vertical high-speed		Horizontal		cooling	Transformer	Light	E-stop protection	power feed
CW	CCW	CW	CCW	CW	CCW					
1	2	3	4	5	6					

Machine Division

1.0 mm black

3 x 0.15 mm²

1.0 mm² (black)

DRILLING & MILLING MACHINE

QUALITY CERTIFICATE

MACHINERYHOUSE

Accuracy Testing List				
1	Flatness	A Horizontal B Cross	0.04/1000 0.04/1000	/
2	Work flatness		0.04/200	0.03
3	Run out of spindle bore	A. End spindle face B. 300mm to spindle face	0.02 0.04	0.01 0.03
4	Kick of spindle		0.02	0.05
5	The perpendicular between spindle and table	A Longitudinal B cross	0.10/200 0.10/200	0.04 0.07
6	The perpendicular between Vertical movement of spindle and table	A longitudinal B Cross	0.10/100 0.10/100	0.05 0.07
7	The parallelism between the work flatness and table	A Longitudinal B Cross	0.05/200 0.05/200	0.03 0.04
8	The straightness of basis "T"		0.03/200	0.02
9	The parallelism between basis "T" and table		0.15/200	0.11
10	The perpendicular between longitudinal move of table and cross move of table.		0.10/200	0.08
11	straightness of vertical movement of knee	A longitudinal B Cross	0.05/200	0.05
12	The perpendicular between bedway and vertical guideway	A longitudinal B Cross	0.10/200 0.10/200	0.04 0.07
13	The parallelism between table and ram moving		0.10/200	0.05
14	The parallelism between table and roating plate rotate	left 30° 0° right 30°	0.10/200	0.04 0.07
15	The parallelism between spindle and worktable		0.10/200	/
16	The parallelism between cross move of work table and spindle	A longitudinal B Cross	0.10/200 0.10/200	/
17	The parallelism between the guideway of ram and spindle	A longitudinal B Cross	0.10/200 0.10/200	/
18	Coaxialism between the hole of surporthilt and axis of spindle	A longitudinal B Cross	0.10 0.10	/